

Test Facility for the Carbonization of Biomass

Background

The electric power industry is promoting the use of biomass co-firing in coal-fired power plants, and assumes that approximately 400,000 tons of woody biomass is consumed per year. However, the co-firing rate remains at a few percent due to the grindability of woody biomass being substantially lower than that of coal. If biomass grindability is improved and co-fired at a high mixing rate, there will be a considerable reduction in power plant CO₂ emission. Biomass carbonization is one of the technologies which enable biomass co-firing at a high mixing rate in coal-fired power plants. By carbonizing the woody biomass, some advantageous effects such as improvement of grindability, increased

heat value and water repellency are expected. On the other hand, there are some issues to resolve such as the reduction of heat loss in the biomass carbonization process, the suppression of spontaneous ignition and the control of pulverization during transportation and storage of carbonized biomass. The aim of this test facility is optimization of carbonization conditions such as temperature, the residence time in the carbonization process and the moisture/size of raw biomass from the viewpoint of selection of raw biomass, advantage of carbonization, reduction of energy consumption and ensuring safety of carbonized biomass.

Outline

The facility is capable of carbonizing high moisture biomass in addition to low moisture biomass by installing a hot-air dryer and two types of conveyance systems for biomass moisture. In order to analyze the heat balance of the carbonization process and to understand carbonization performance, process information (over 170 points

of measurements such as temperature, pressure and flow rate) can be stored in the data acquisition system. The analysis of pyrolysis gas components is also possible. In terms of achieving commercial scale, an indirect heating type rotary kiln was adopted as a carbonizer.

Specifications

- High-temperature rotary kiln for carbonizing machine
 - Feed rate of raw biomass : Max. 200 kg/h (moisture 30%)
 - Carbonization temperature : 200 to 600 degC
 - Residence time of biomass : 20 to 60 min
- Hot-air dryer
 - Feed rate of raw biomass : Max. 500 kg/h (moisture 80%)
 - Moisture of dried biomass : 10 to 30%
- Analyzing device
 - Micro GC, GS, HPLC, UV-Vis-NIR

[Location and date of installation]

Yokosuka area / July, 2013

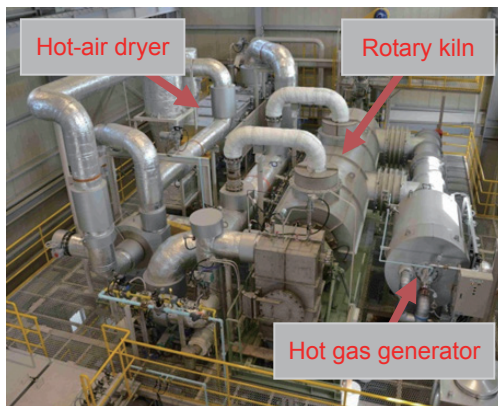

Photo 1: External view of the test

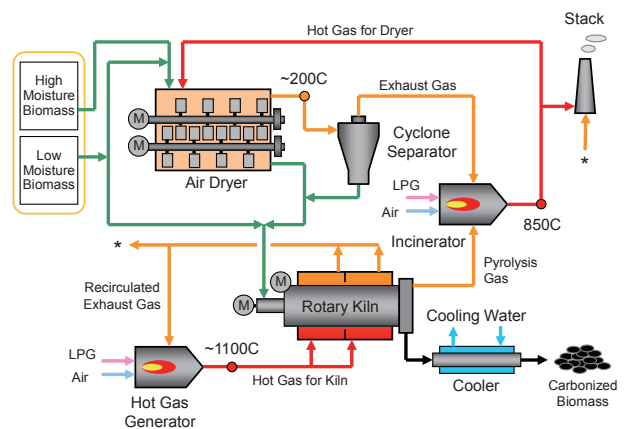

Fig. 1: Schematic diagram of the test facility